

# TWINCUT

CH 702 388

411CT

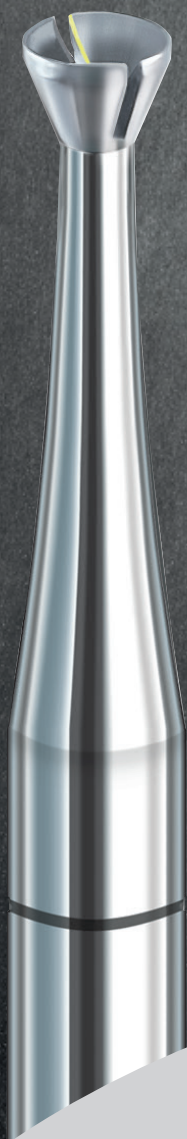

411T



round off • smoothen • shorten

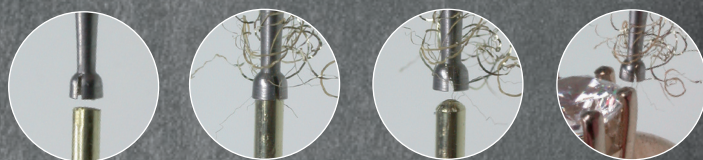

... in one milling operation.

BUSCH concave cutters with our specific TWINCUT blade geometry realize this with ease. Their strength lies in quick and precise milling without chip jamming. The specialists for chatons.



There is no substitute for quality

## Advantages of TWINCUT:

- Rapid removal of material due to the effective TWINCUT blade geometry
- Rapid discharge of material through the two chip channels
- Easy handling: simply position the tool and start milling with low pressure
- Filigree cutter walls create additional room for closely spaced claws
- High cost-efficiency due to the robust TWINCUT blade geometry

## The TWINCUT blade

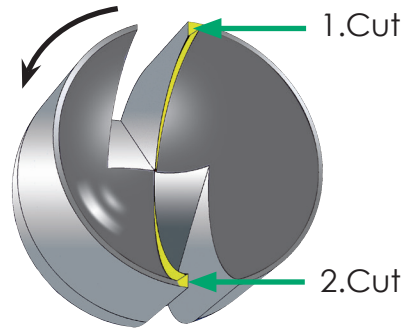

New

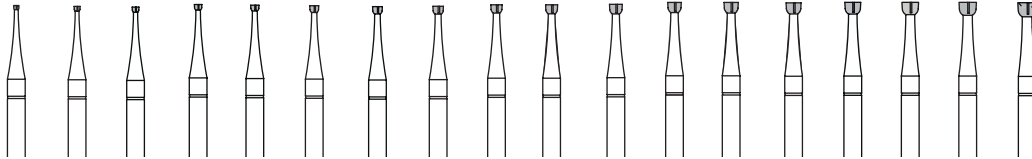

411T	007	008	009	010	011	012	013	014	015	016	017	018	019	020	021	022	023	025
D1	0,70	0,80	0,90	1,00	1,10	1,20	1,30	1,40	1,50	1,60	1,70	1,80	1,90	2,00	2,10	2,20	2,30	2,50
D3	0,55	0,65	0,75	0,85	0,95	1,04	1,14	1,24	1,34	1,43	1,53	1,62	1,72	1,81	1,91	2,01	2,10	2,34
L1	0,55	0,65	0,70	0,75	0,78	0,90	0,98	1,05	1,10	1,20	1,28	1,35	1,42	1,48	1,55	1,63	1,72	1,87

New

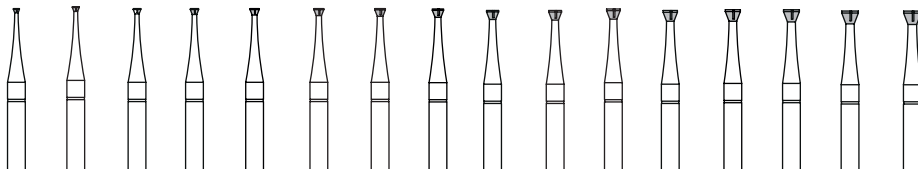

411CT	008	009	010	011	012	013	014	015	016	017	018	019	020	021	022	023
D1	0,80	0,90	1,00	1,10	1,20	1,30	1,40	1,50	1,60	1,70	1,80	1,90	2,00	2,10	2,20	2,30
D3	0,65	0,75	0,85	0,95	1,04	1,14	1,24	1,34	1,43	1,53	1,62	1,72	1,81	1,91	2,01	2,10
L1	0,49	0,57	0,64	0,72	0,79	0,87	0,96	1,05	1,13	1,21	1,29	1,37	1,45	1,54	1,60	1,69

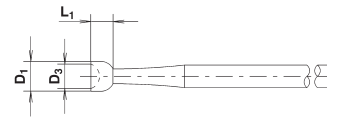

D<sub>1</sub> = working part diameter mm  
 D<sub>3</sub> = inner working part diameter mm  
 L<sub>1</sub> = working part length mm

Recommended speed:  
 2.500 - 7.000 min<sup>-1</sup>

### Set 411T 008-020

set from size 008 up to 020  
 (without 019)



### Set 411CT 008-020

from size 008 up to 020  
 (without 019).



### AKTIV GULD A/S

Vallensbækvej 46  
 2625 Vallensbæk  
 Denmark

ag@aktivguld.com  
 Telefon +45 4366 2000

www.aktivguld.com